

Introduction to CNC

Why CNC

- Consistency of workpieces produced
- Faster workpiece machining
- Lowered skill level of machinist
- Complexity of workpieces to be machined
- Flexibility, faster turn-around, and smaller lots

- **2 Axis**
 - if all the cutting takes place in the same plane. In this case, the cutter does not have any capability of movement in the Z (vertical) plane. In general the X and Y axes can “interpolate” together simultaneously to create angled lines and circular arcs.
- **2.5 Axis**
 - if all the cutting takes place entirely in planes parallel to the principal plane but not necessarily at the same height or depth. In this case, the cutter can move in the Z (vertical) plane to change levels, but not simultaneously with the X,Y movements. An exception might be that the cutter can interpolate helically, that is do a circle in X.Y while moving simultaneously in Z to form a helix (for example in thread milling). A subset of the above is that the machine can interpolate any 2 axes together simultaneously, but not 3. This does make a limited number of 3D objects possible, by cutting in the XZ or YZ planes, for example, but is much more limited than full 3 axis interpolation.
- **3 Axis**
 - if your cutting requires simultaneous controlled movement of the X,Y,Z axes, which most free-form surfaces require.
- **4 axis**
 - if it includes the above plus 1 rotary axis movement. There are two possibilities - 4 axis simultaneous interpolation (also known as true 4th axis) or just 4th axis positioning, where the 4th axis can reposition the part between 3 axis operations, but does not actually move during the machining.
- **5 axis**
 - if it includes the above plus 2 rotary axis movements. In addition to “true 5 axis machining” (5 axes moving simultaneously while machining), you also commonly have “3 plus 2” or 3 axis machining + 2 separate axes positioning only, as well as in rarer cases “4 plus 1” or continuous 4 axis machining + a single 5th axis positioning only. Complicated, isn't it...

CNC router



CNC milling machine



Roland SRM 20



<https://www.youtube.com/watch?v=sBtIOHmuPrU>

Basic Machine Axes: 3 axis

- Cartesian Robot: 3 axis
 - X – axis (table left and right)
 - Y – axis (table in and out)
 - Z – axis (usually the extruder axis)

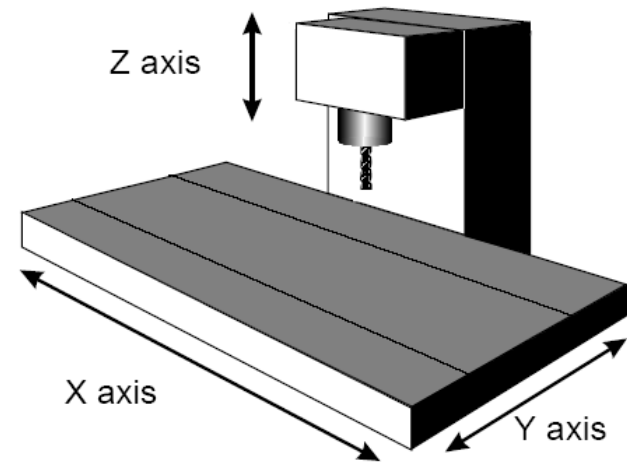
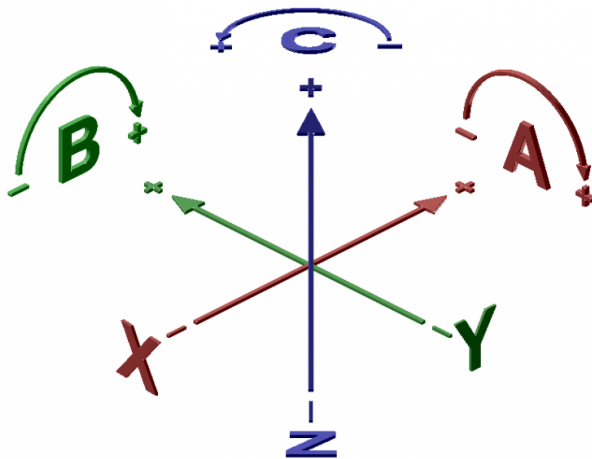

- Machine home

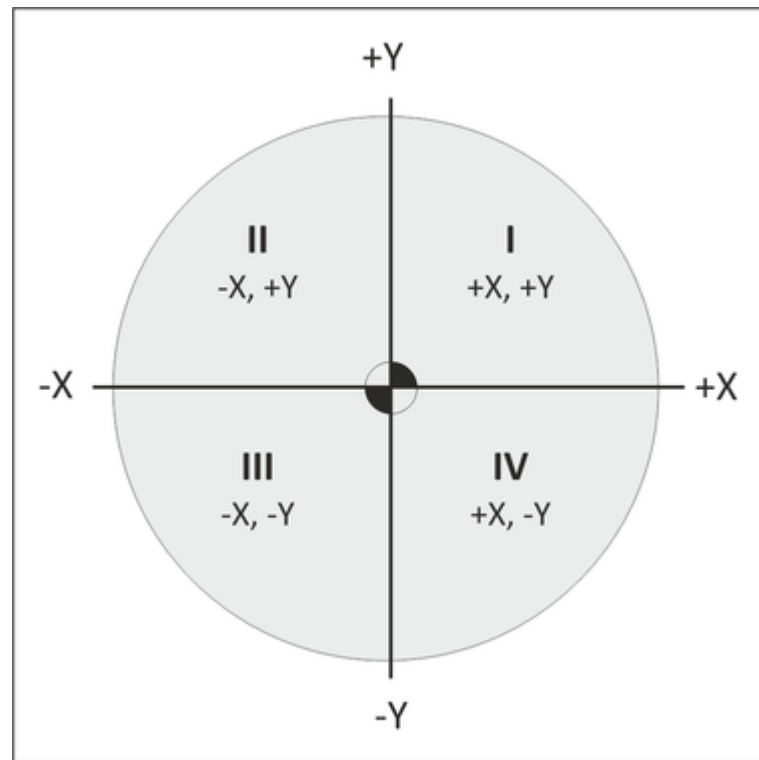

Work coordinate system

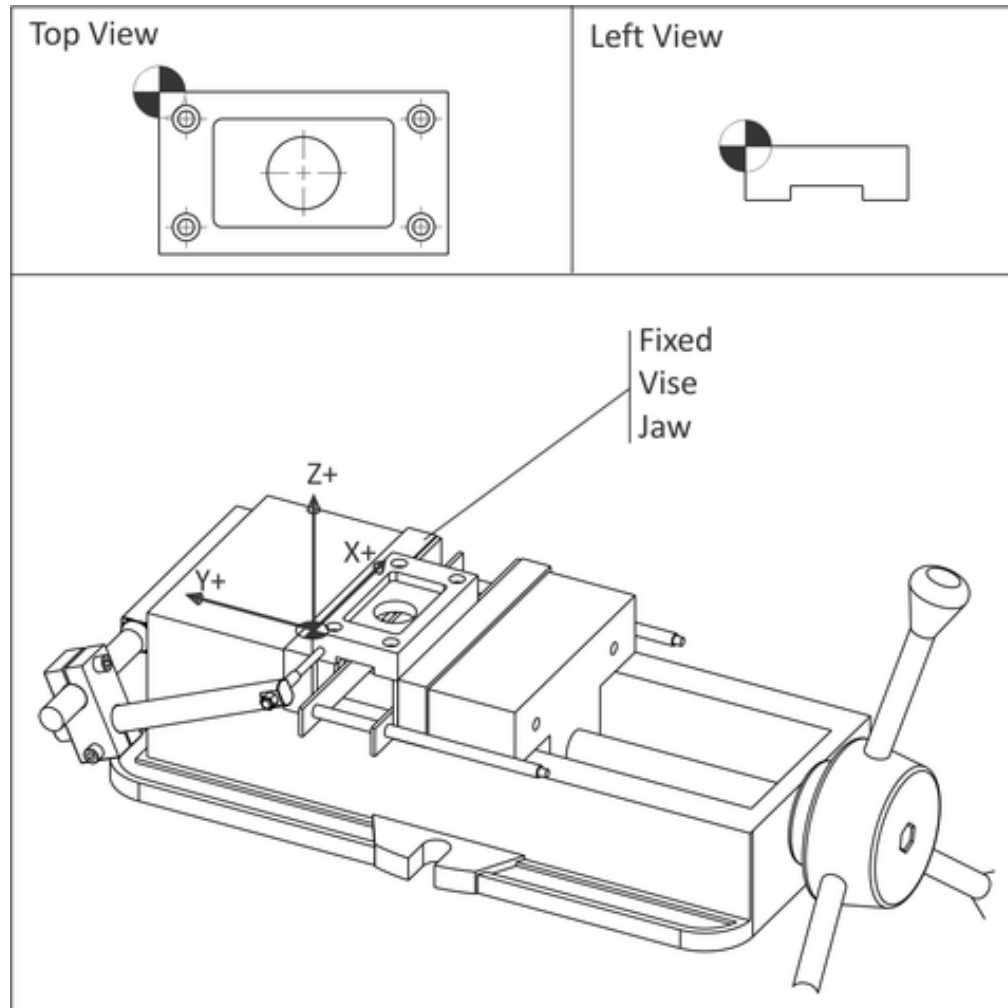

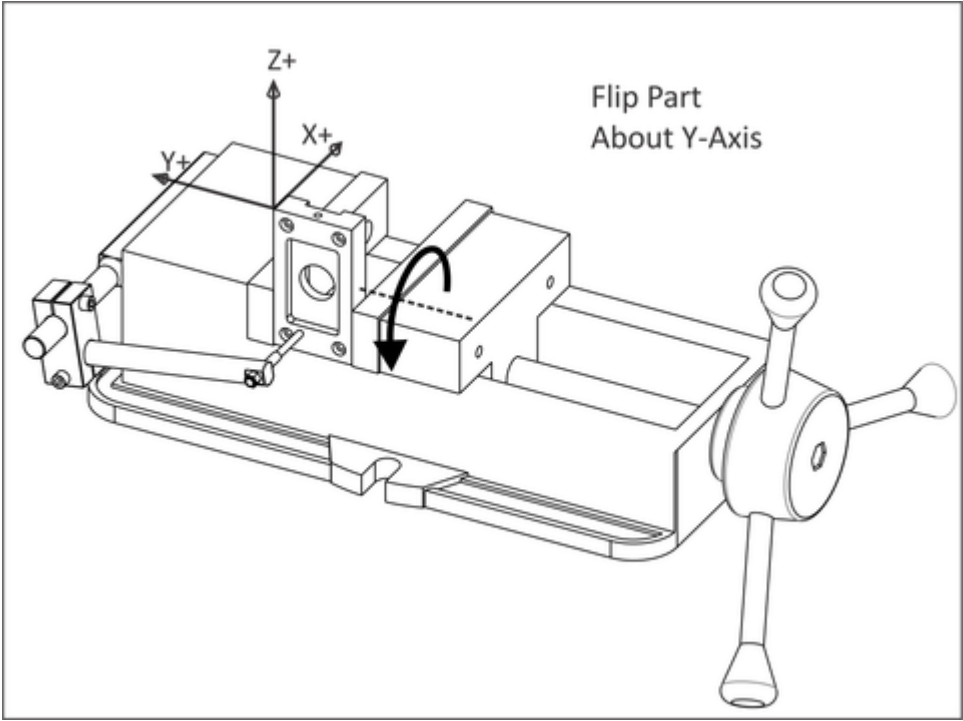

Tool reference point

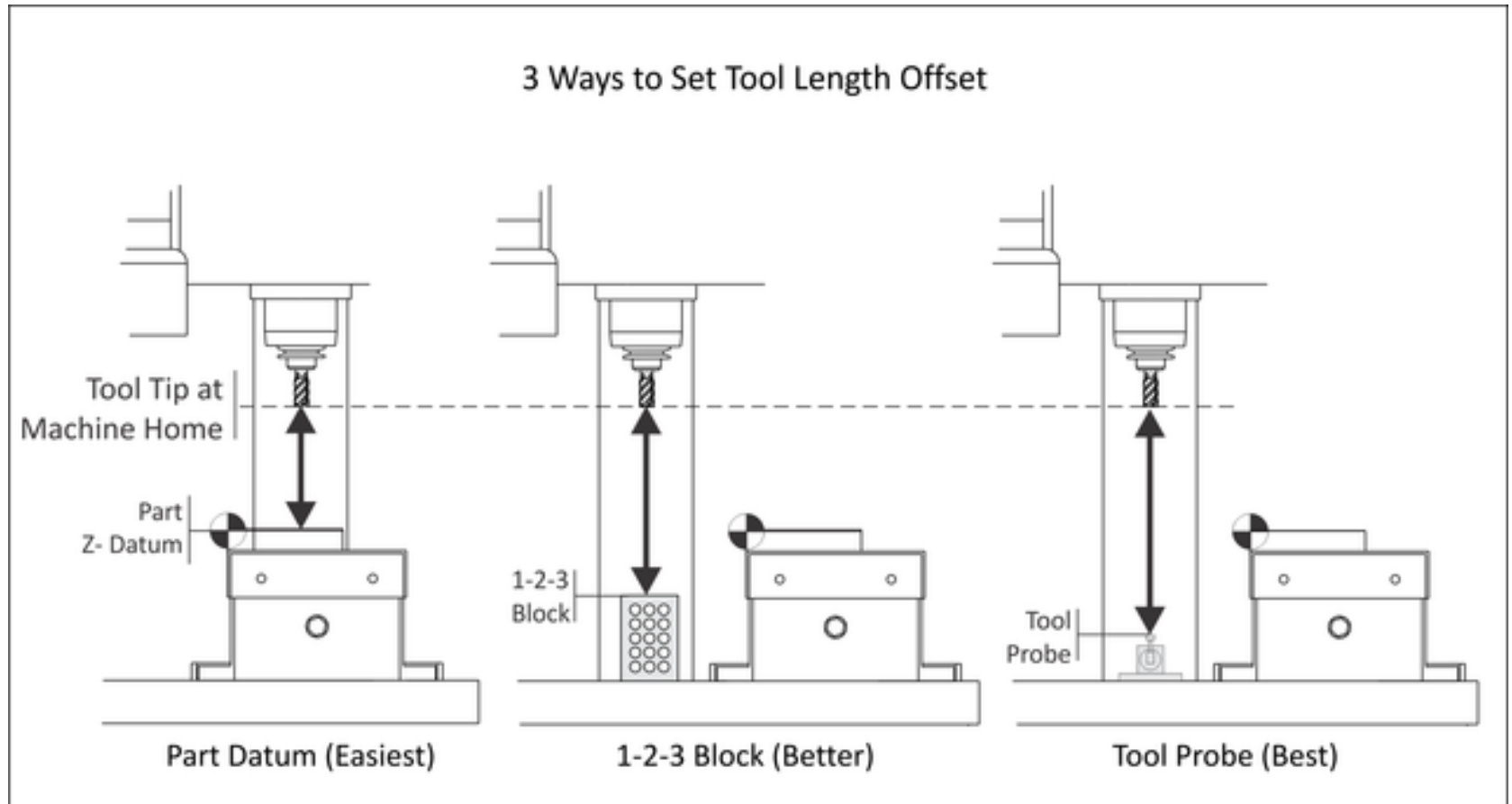

Tool reference point

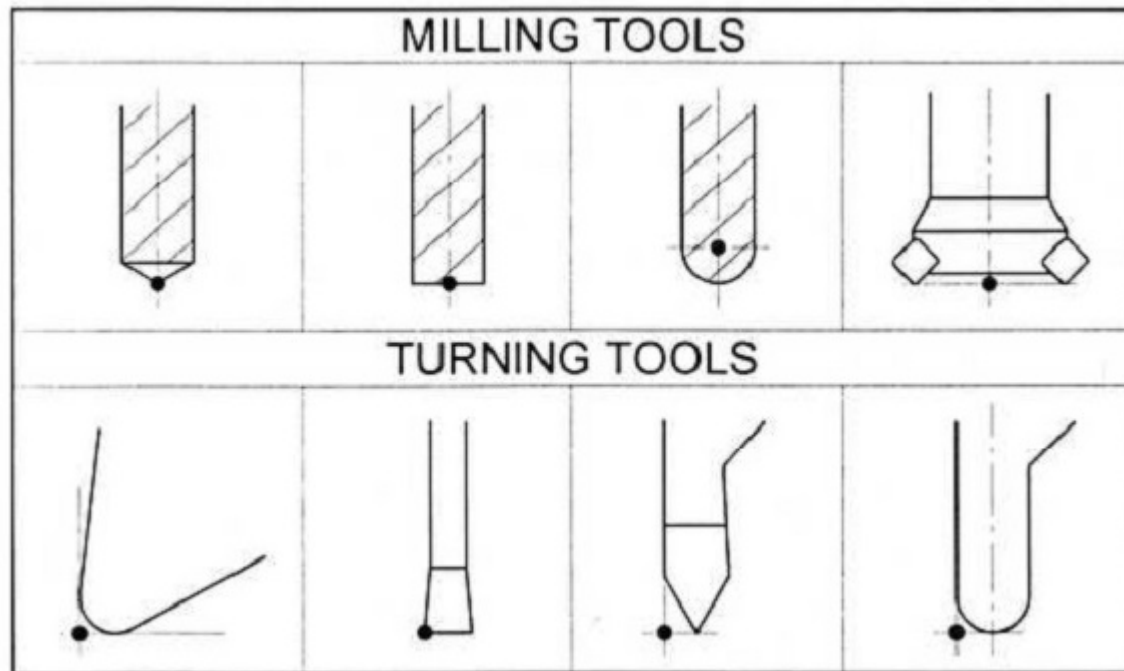

SolidCAM2008 R 12 provides you with a number of new tool types (see the illustration below). Also **SolidCAM2008 R 12** provides you with a number of improvements to the existing tool types to better describe the real tools (e.g. adding the **Arbor diameter** parameter).

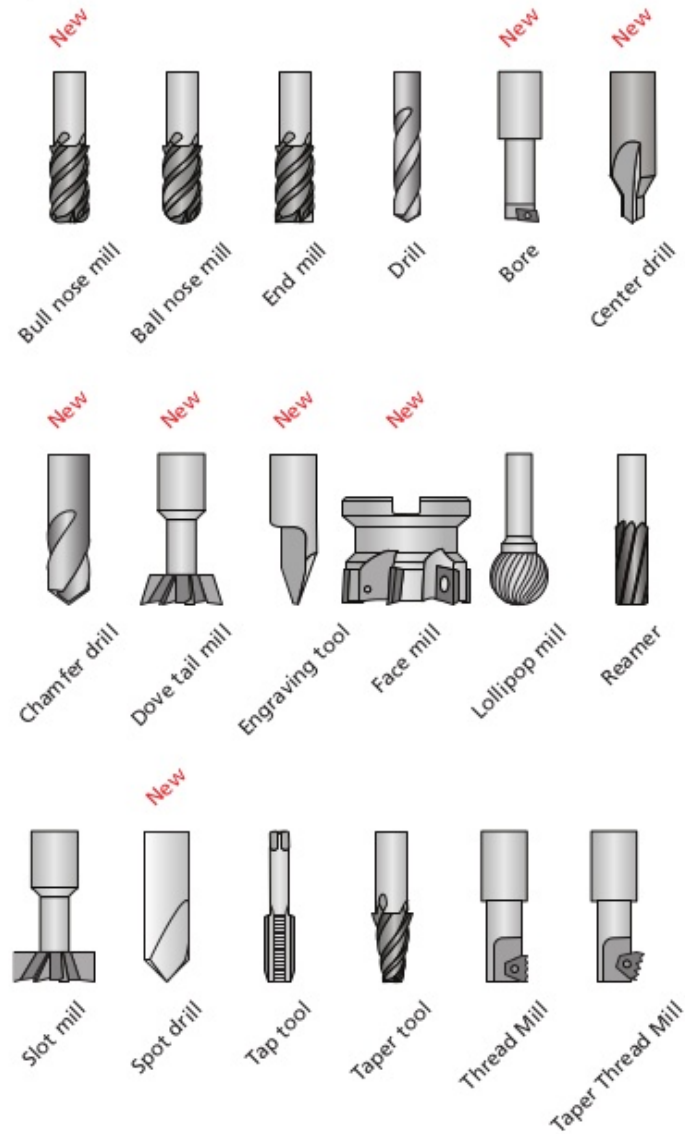

$V_c = \frac{n * \pi * D}{1000}$
$n = \frac{V_c * 1000}{\pi * D}$
$V_f = n * F_z * z$
$F = z * F_z \quad F = \frac{V_f}{n}$
$F_z = \frac{F}{z}$
$T_c = \frac{L}{V_f}$

formule per fresare

V_c =velocità di taglio in m/minuto
 n =numero di giri dell'utensile al minuto
 D =diametro dell'utensile in millimetri
 z =numero dei denti dell'utensile
 F_z =avanzamento in mm/giro per un dente
 F =avanzamento utensile al giro in mm/giro
 V_f =avanzamento tavola in mm/minuto
 T_c =tempo di contatto utensile in lavoro
 L =lunghezza del lavoro
 π =pigreco (3,14)

Material type	Meters per min (MPM)	Surface feet per min (SFM)
Steel (tough)	15–18	50–60
Mild steel	30–38	100–125
Cast iron (medium)	18–24	60–80
Alloy steels (1320–9262)	20–37	65–120
Carbon steels (C1008–C1095)	21–40	70–130
Free cutting steels (B1111–B1113 & C1108–C1213)	35–69	115–225
Stainless steels (300 & 400 series)	23–40	75–130
Bronzes	24–45	80–150
Leaded steel (Leadloy 12L14)	91	300
Aluminium	75–105	250–350
Brass	90–210	300–700 (Max. spindle speed)
Plastics (Derlin)	150–210	500-700

Clamping (Staffaggio)



Staffaggio

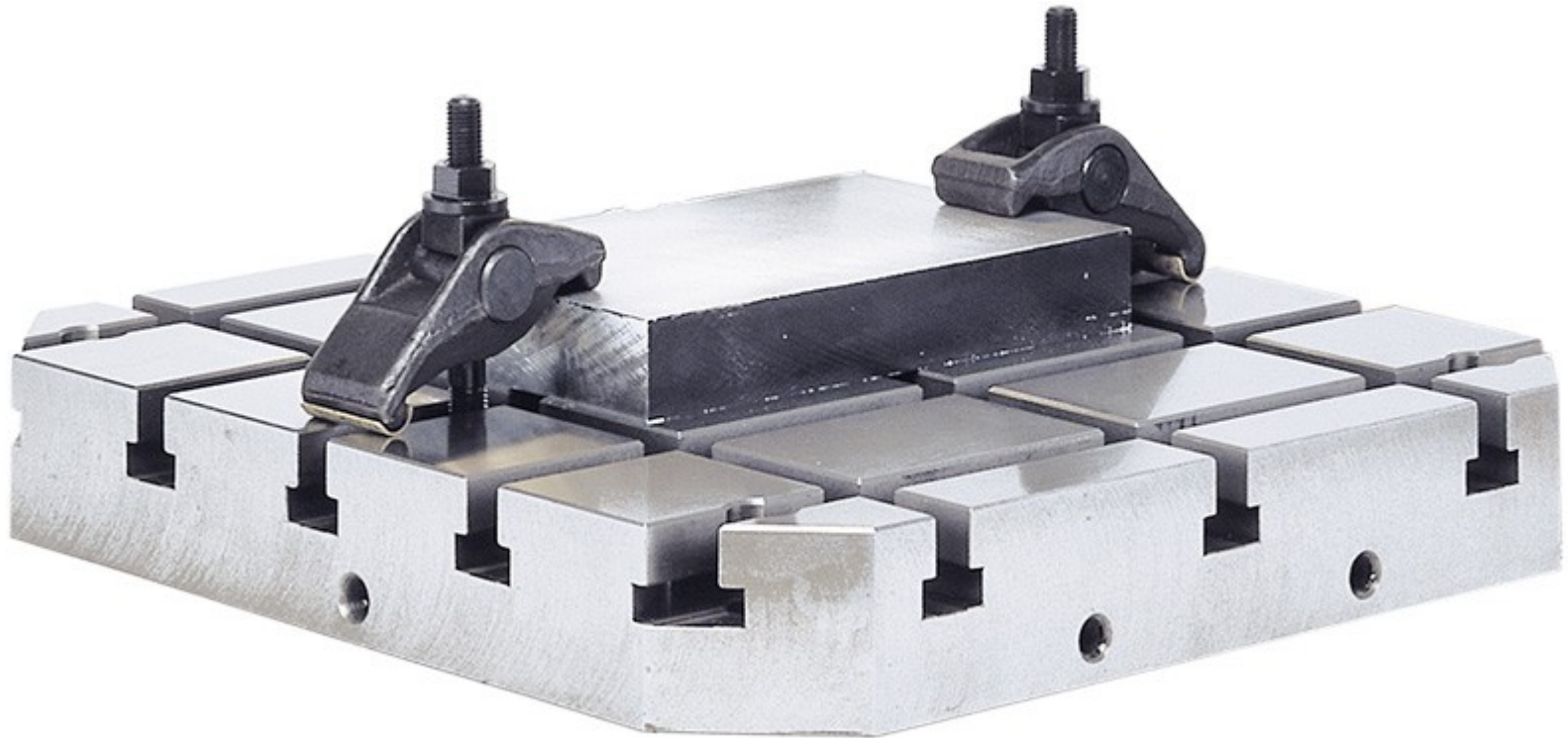



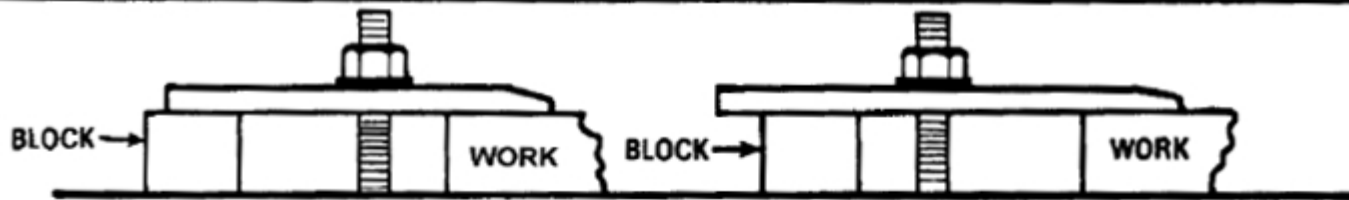

CORRECT

INCORRECT

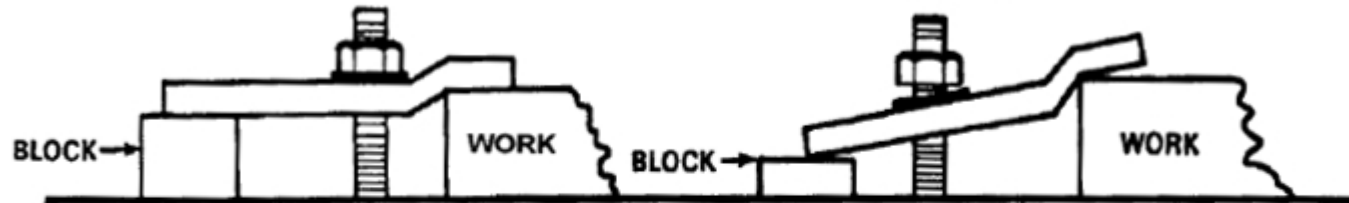

CORRECT

INCORRECT

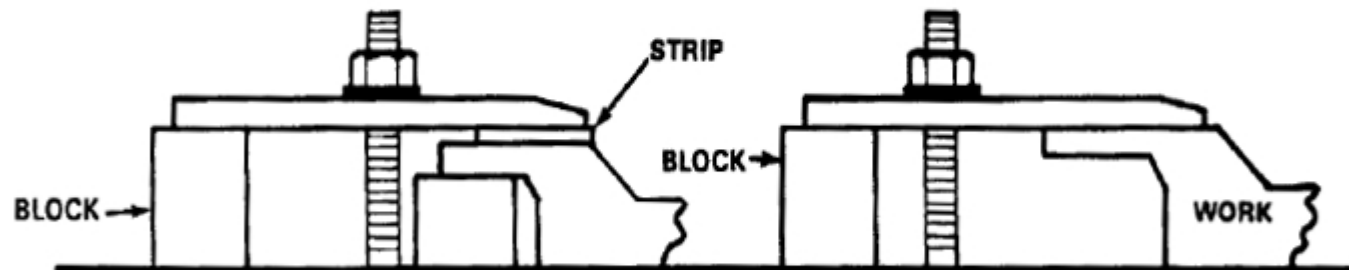

CORRECT

INCORRECT

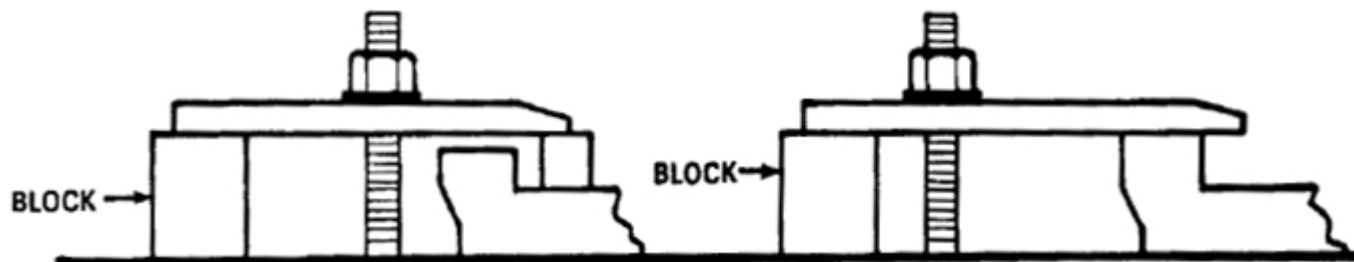

CORRECT

INCORRECT

Martire



Workbenching tabs

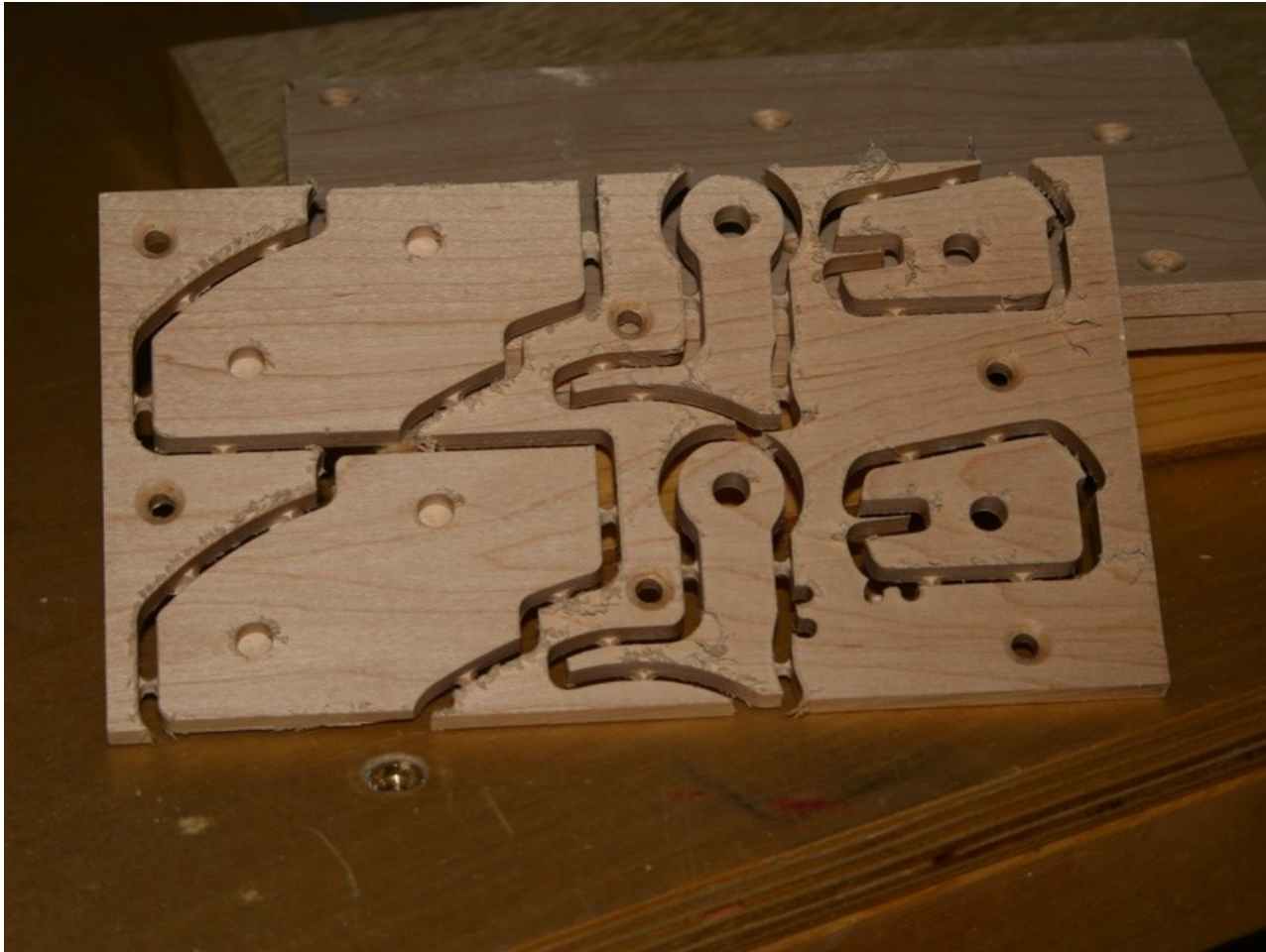

Vacuum table



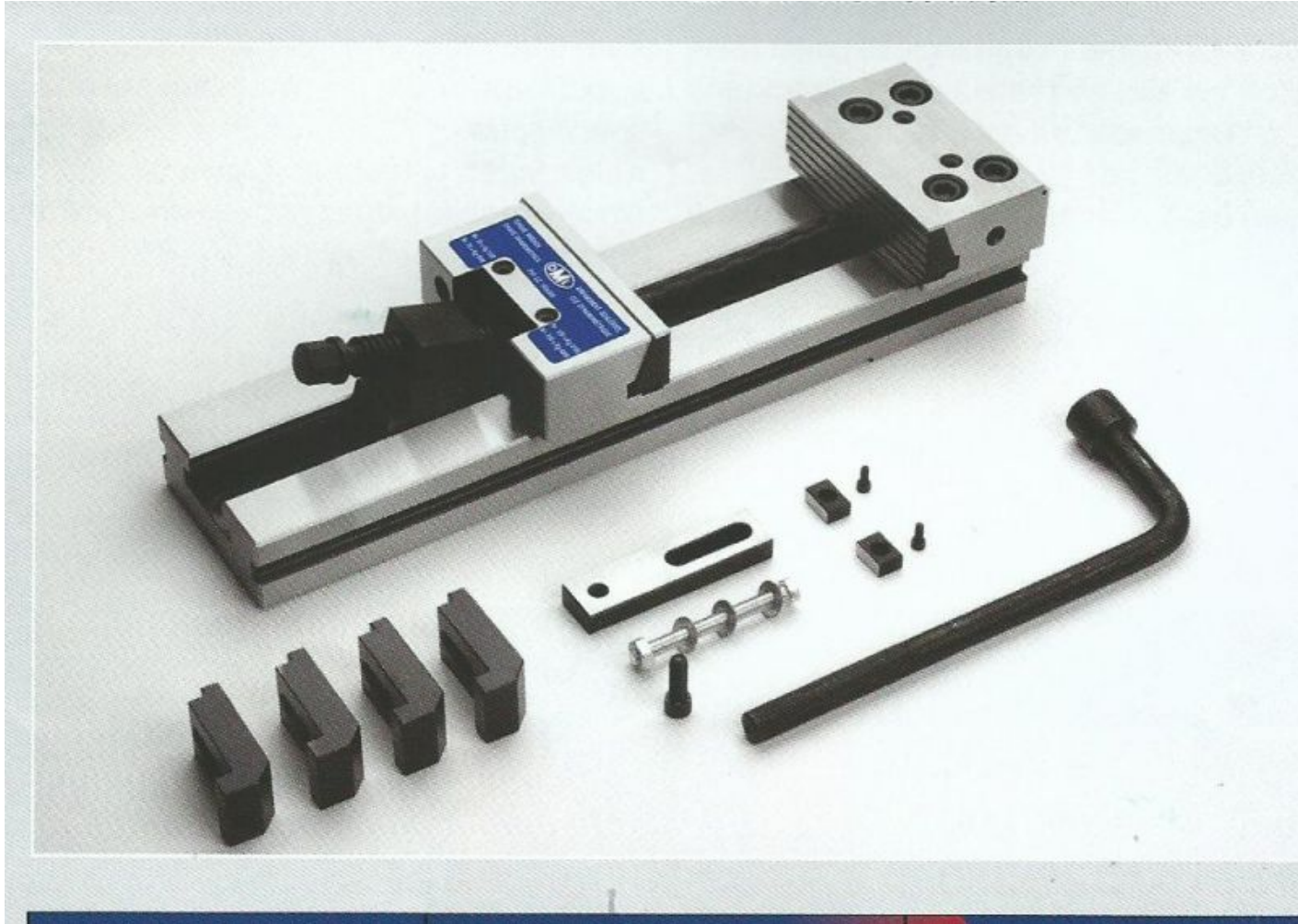

G-CODE

- G – Code Programming
- Originally called the “Word Address” programming format.
- Processed one line at a time sequentially.

Word address format

- Word address was developed as a tape programming format.
 - Another name for “word address” is “variable block” format, so named because the program lines (blocks) may vary in length according to the information contained in them.
 - Earlier tape formats required an entry for all possible machine registers. In these earlier formats, a zero was programmed as a null input if the register values were to be unaffected, but in word address, the blocks need only contain necessary information. Although developed as a tape format, word address is used as the format for manual data input on many CNC machines.
- Addresses
 - The block format for word address is as follows:
 - N ... G ... X ... Y ... Z ... I ... J ... K ... F ... H ... H ... S ... T ... M ...
 - Only the information needed on a line need be given. Each of the letters is called an address (or word)

Common Format of a Block

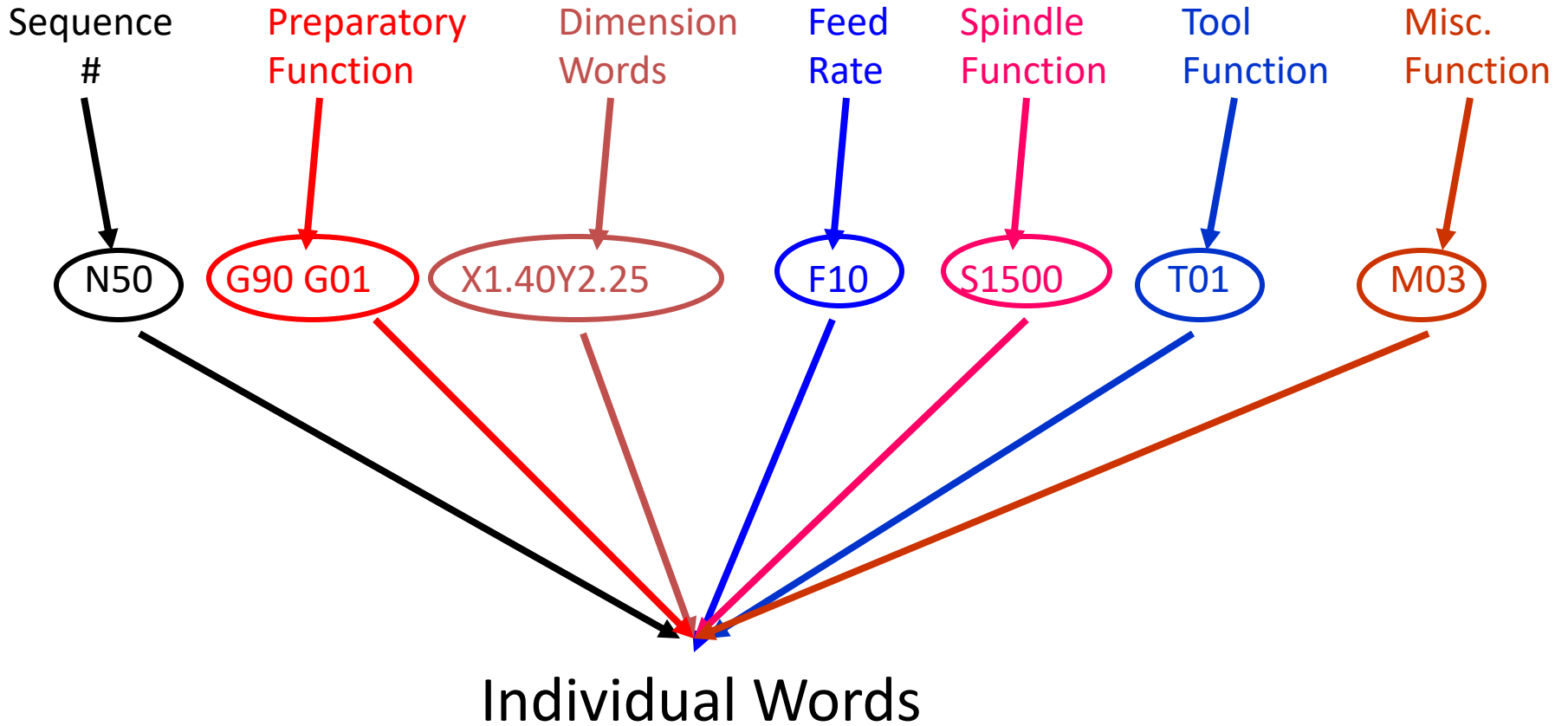

Word address

- Reserved Code Words Worksheet
 - N – Sequence or line number
 - G – Preparatory function
 - ...
- Dimension Words:
 - X
 - Y
 - Z

Word Address 1/3

- N – Sequence or line number
 - A tag that identifies the beginning of a block of code. N numbers are ignored by the controller during the program execution. It is used by operators to locate specific lines of a program when entering data or verifying the program operation.
- G – Preparatory function
 - G words specify the mode in which the milling machine is to move along its programmed axes. Preparatory functions are called prep functions or, more commonly **G codes**

Word Address 2/3

- Dimension Words
 - X – Distance or position in X direction
 - Y – Distance or position in Y direction
 - Z – Distance or position in Z direction
- M – Miscellaneous functions
 - M words specify CNC machine functions not related to dimensions or axial movements.

Word Address 3/3

- F – Feed rate (inches per minute or millimeters per minute)
 - Rate at which cutting tool moves along an axis.
- S – Spindle speed (rpm – revolutions per minute)
 - Controls spindle rotation speed.
- T – Tool number
 - Specifies tool to be selected.

G Word

- G words or codes tell the machine to perform certain functions. Most G words are modal which means they remain in effect until replaced by another modal G code.

Part program structure

- Comments and information
- Program Start
- Load Tool
- Spindle On
- Coolant On
- Rapid to position above part
- Machining operation
- Coolant Off
- Spindle Off
- Move to safe position
- End program

Comments and information

- Program file name.
- Program author
- Version date
- Modification history--a line for each version telling what changed, who made the changes, and the date.
- Machine and control the program is intended for
- Units: inches or mm
- Setup information: What stock material is expected, what size, etc.?
- Work Coordinates: What's expected by way of work coordinates?
Where is Part Zero?
- Customer info: Job shops will want information about what customer and job # the program is part of.
-

- http://wiki.fablabtoscana.it/SB_CG1/G-Code

Feed and speed

- http://wiki.fablabtoscana.it/SB_CG1/Feed_%26_Speeds

Common G Codes

- G00 – Rapid positioning mode
 - Tool is moved along the shortest route to programmed X,Y,Z position. Usually NOT used for cutting.
- G01 – Linear Interpolation mode
 - Tool is moved along a straight-line path at programmed rate of speed.
- G02 – Circular motion clockwise (cw)
- G03 – Circular motion counter clockwise (ccw)

M Word

- M words tell the machine to perform certain machine related functions, such as: turn spindle on/off, coolant on/off, or stop/end program.

LINUX CNC

Linux PC

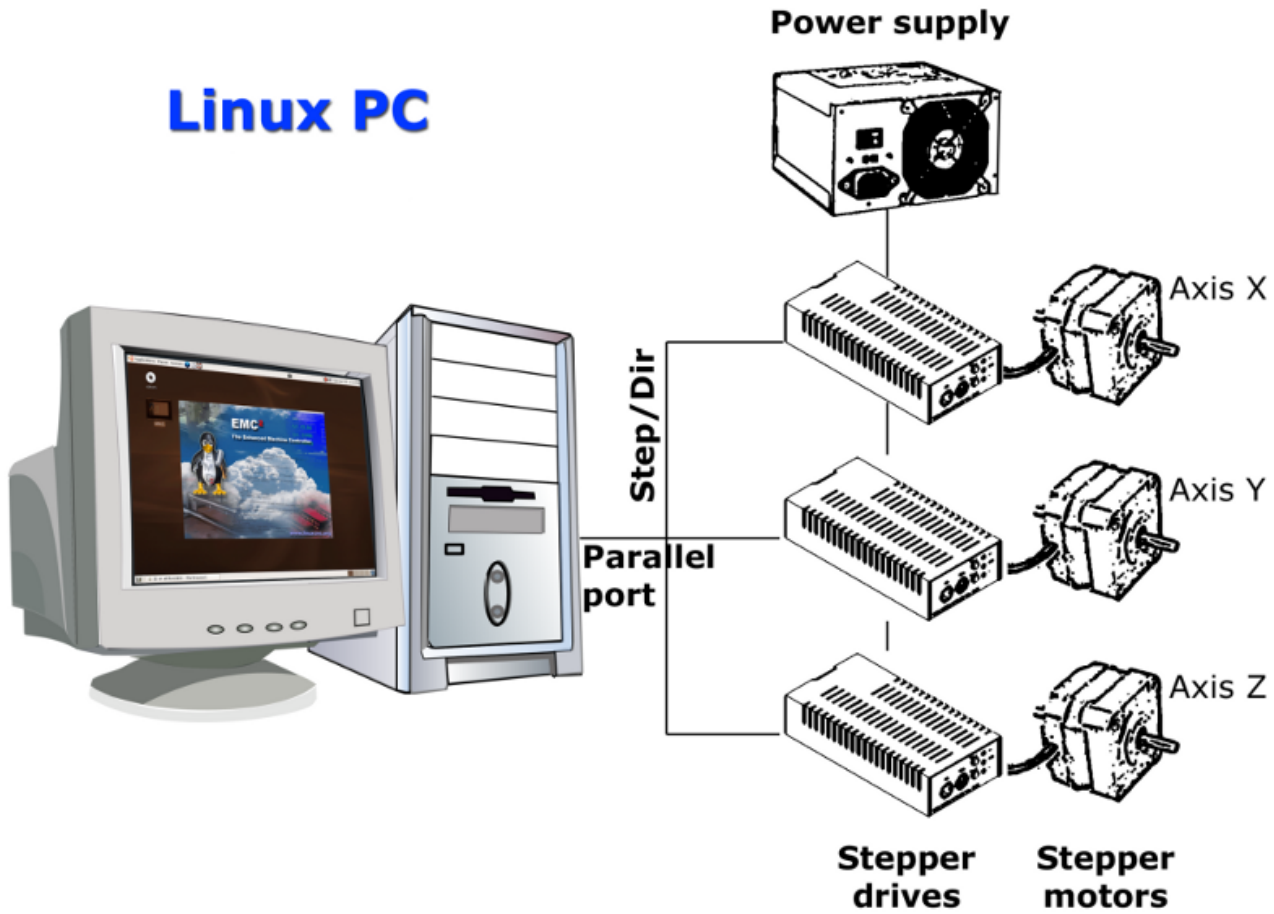

LINUX CNC

gmoccapy for linuxcnc 0.9.9.3

X G54 Abs 44.596 DTG 0.000
Y G54 Abs 46.420 DTG 0.000
Z G54 Abs -20.060 DTG 0.000
C G54 Abs 0.00 DTG 0.00

Jog. Geschw. 300

Verfahren: Y+, Z+, C+, X-, X+, Y-, Z-, C-

Schrittweite: Durchgehend, 1mm, 0.1mm, 0.01mm, 0.001mm, 1.2345in

Werkzeug Info: Werkzeugnr. 1, Durchm. 4,5000, Offset Z 0.000
4.5 mm 3 flute cutter

Max. Geschw. Vel. 0, 14040

Kühlung: S 2500, 100%

Spindel [U/min]: S 2500, 100%

G-Code: M0 M3 M8 M48 M53 M61, G8 G17 G21 G40 G49 G54 G64 G80, G90 G91.1 G94 G97 G99

Programm: ./././n...ols_with_cutter_radius_compensation.ngc

Hinweise

LINUX CNC

The screenshot displays the Linux CNC software interface. On the left, a text window shows the G-code program for a circular pocket. The program includes parameters such as units (G20 inches), tool number (1), tool description (2 flute endmill), tool diameter (0.5000), spindle RPM (5000), pocket diameter (3.6600), and center locations (X=0.0000, Y=0.0000). The feed rate is set to 60.00 inches/minute and the stepover is 0.2500. The Z-axis parameters include a clear location of 0.1000, start location of 0.0000, and an adjusted depth of cut of 0.1000.

The main window shows a 2D visualization of the circular pocket on a grid. The pocket is centered at (0,0) with a diameter of 3.6600 inches. The Z-axis is shown with a depth of 0.1000 inches. The tool path is indicated by concentric circles.

The bottom panel contains the control interface. On the left, there are buttons for CYCLE START, SINGLE BLOCK, FEEDHOLD, COOLANT, M01 BREAK, STOP, and RESET. In the center, the WORK and DTG coordinates are displayed: X: -0.0829, Y: 0.7454, Z: 9.6548, and A: 0.0000. On the right, there are controls for STEP (0.001 to 0.000), a 40% JOG speed indicator, SPINDLE RANGE (CCW, STOP, CW), FEEDRATE (20.0 /MIN), and tool selection (T 0, M6 S43, GO TO G30). The status bar at the bottom indicates the current G-code (G54 G90 G20 G80 G40 G94 G97) and the software version (MILL5M V12A-96-64582873).